

Parts needed to mount the LIT-L extrusion

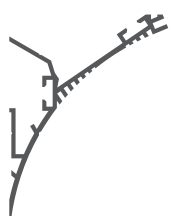

Mounting strip (A)



End caps (B)



Extrusion (C)



End caps (D)



Cover (E)



LED strip (F)



Silicone cord (G)

Tools needed for mounting:

- drill
- dcrewdriver
- screws
- metal saw
- glue
- plaster
- paint

WARNING! All LED strips should be connected to a 12 V or 24 V power supply.

IMPORTANT: The mounting instructions present the basic form of assembly. More methods and related accessories can be found at www.KlusDesign.eu

1. Cut the mounting strip (A) to the required length and the extrusion (C) min. 2 cm shorter. This will enable mounting end caps and running the cable inside the fixture.

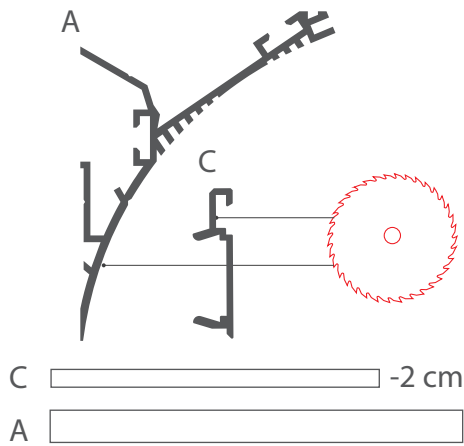

2. Drill screw holes and holes for power cables in the mounting strip (A).

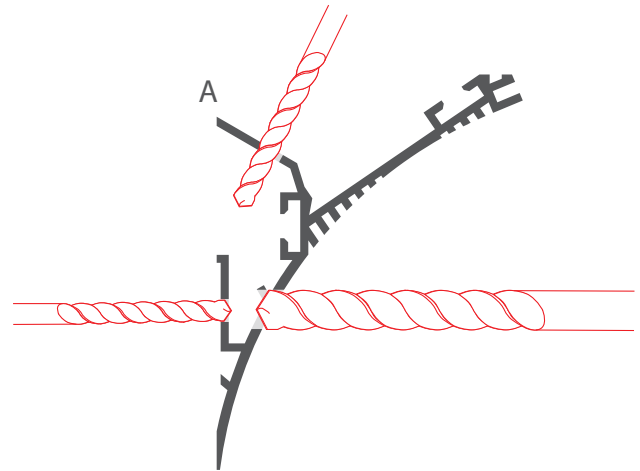

3. Attach the mounting strip (A) to the mounting surface with screws suitable for the material (wood, plasterboard etc.). Feed the power cables.

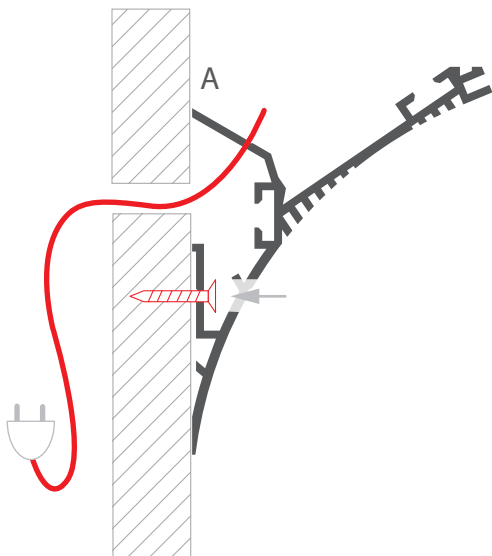

4. Insert the end caps (B) into the mounting strip (A) and cover all with plaster finish.

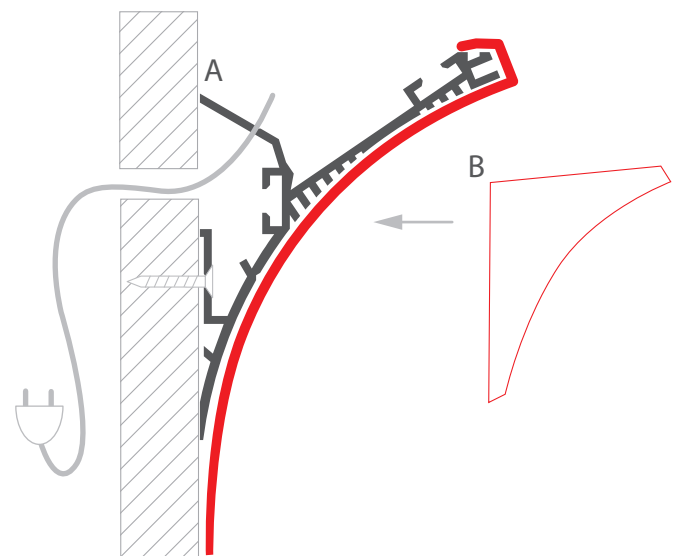

5. Install the LED strip (F), lead out the cable and insert the cover (E) into the extrusion (C). Insert the end caps (D). The cable can be run through a hole drilled in the extrusion or in the end cap.

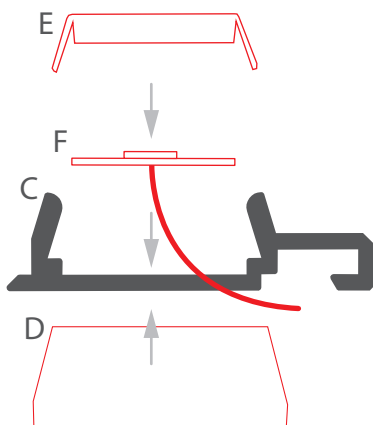

6. Mount the extrusion (C) in the mounting strip (A) and secure with the silicone cord (G).

